

Using the ECOLEC Series 100 dual and three phase meters as uni-phase Meters

Introduction

The dual phase EC12x and three phase EC13x meters in the ECOLEC 100 Series have been designed to measure energy in dual phase three wire and three phase four wire systems respectively. These multiple phase meters can however be used to measure the consumption of loads that are all fed from the same phase provided careful thought is given to the Neutral return currents that arise.

Neutral return currents

In three phase and dual phase supplies, the phase difference between the line voltages is arranged in such a way that the sum of the line voltages is equal to zero. If the separate line currents are equal and at equal power factors (same phase shift relative to their respective line voltage) the resulting neutral current, which flows through the neutral pole of the meter, will be exactly zero. In reality power factors are not the same and the magnitude of the currents that flow are not normally equal. This is known as phase imbalance. In properly designed dual and three phase installations where phase balance limits are not exceeded, the sum of the phase currents will always be less than the maximum current rating of the meter. This means that for proper dual and three phase installations, the Neutral return current is always within the maximum current specification of the meter when it is flows back through the neutral pole. This is shown in Figure 1.

If a three phase or dual phase meter is used to measure loads operating from the same phase, the Neutral return current will not be reduced by the cancellation effect of the phase differences. Instead, the currents will sum arithmetically because there is not a significant phase difference. This can result in a Neutral return current reaching twice the meter's maximum rating for a dual phase meter (120 Amps with an EC12x), or three times the meter's maximum rating for a three phase meter (180 Amps with an EC13x). These excessive currents will cause the Neutral pole of the meter to overheat resulting in a fire hazard in extreme cases or reduction in product lifetime in marginal cases. This situation must be avoided at all costs.

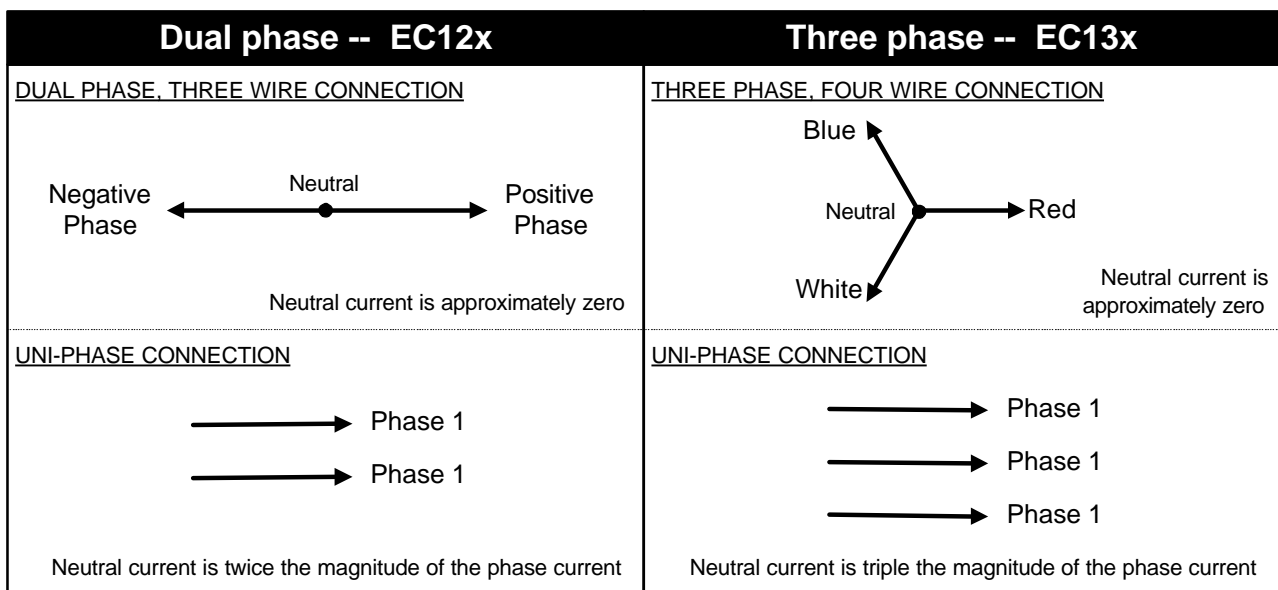

Figure 1. Vector diagrams of different meter connection methods

Using the ECOLEC Series 100 dual and three phase meters as uni-phase Meters

There are however, two methods by which the ECOLEC meters can be deployed as multiple meters on a single phase supply. These methods are described below and typical applications are shown in Figure 2. The application of a conservative ADMD value has been applied to the upstream breaker ratings.

Method 1: Maximum current de-rating

When the meters are used to measure loads on the same phase, the arithmetic sum of the currents must not exceed the maximum rating of the meter. Thus, a three phase EC13x meter can be used if the maximum current per meter is limited to 20 Amps. Similarly, a dual phase EC12x meter can be used if the maximum current per meter is limited to 30 Amps. This can be achieved with CBI's range of Precision Breakers or with a properly sized overload pole in the earth leakage device. It is preferable to fit these breakers downstream from the meter as this reduces the likelihood of tampering. This is shown in Figure 2.

Method 2: External Neutral bus-bar and low current Neutral wire

Since the neutral pole of the meter does not contain any measuring circuitry, it is not essential that the Neutral return current is actually routed through the neutral pole of the meter. The incoming Neutral can thus be terminated on a properly rated bus-bar along with the Neutral returns from the loads. The Neutral connection to the meter must then be made with a low current (typically 1 Amp) wire to either the line or load side of the Neutral pole of the meter. In this way the load on each phase can be up to a maximum of 60 Amps because the Neutral return current does not flow through the meter. Note however that this connection method is easy to tamper by simply cutting the low current Neutral wire to the meter.

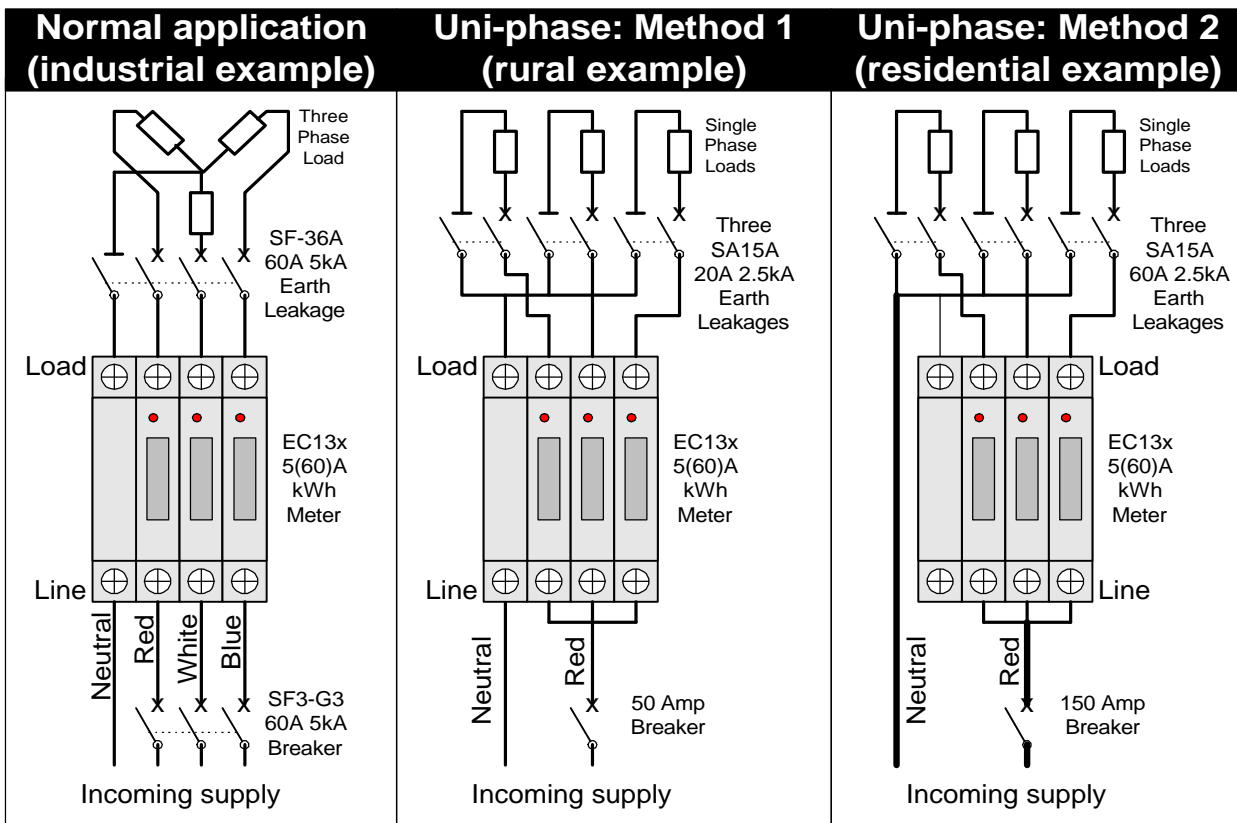

Figure 2. Typical wiring methods for a three phase ECOLEC Series 100 meter

Conclusion

The ECOLEC Series 100 meters can safely be used as Uni-phase meters if they are connected correctly. Proper design of the installation to co-ordinate fault levels and tripping curves must be done.