

Using the SLMS output of the ECOLEC Series 100 Meters

Introduction

The ECOLEC Series 100 meters are equipped with a data output for Automated Meter Reading (AMR) purposes. This Single Line Messaging System (SLMS) output from the meter is transmitted on the Lateral Data Bus (LDB), which consists of two signals namely Neutral and Data. The electrical contacts are contained within circular apertures on the sides of the meter and either side can be used interchangeably. These apertures might be sealed with a removable plug. M3 cheesehead screws with barrel bolts can be used to construct a low cost mechanical and electrical interface to the LDB.

The Data signal is the obtained from the contact within the aperture closest to the LINE terminal of the meter (see Figure 1) and is referenced to the meter's Neutral connection. If the device reading the meter is not referenced to Neutral, optical isolation will be required. The data output by the meter will consist of either consumption pulses every 1/10 of a kilowatt-hour or a serial data stream of power and meter information. The output mode of the meter is determined by the value of a mode selecting resistance applied to the LDB. The meter checks this impedance once every second and dynamically alters its output mode accordingly.

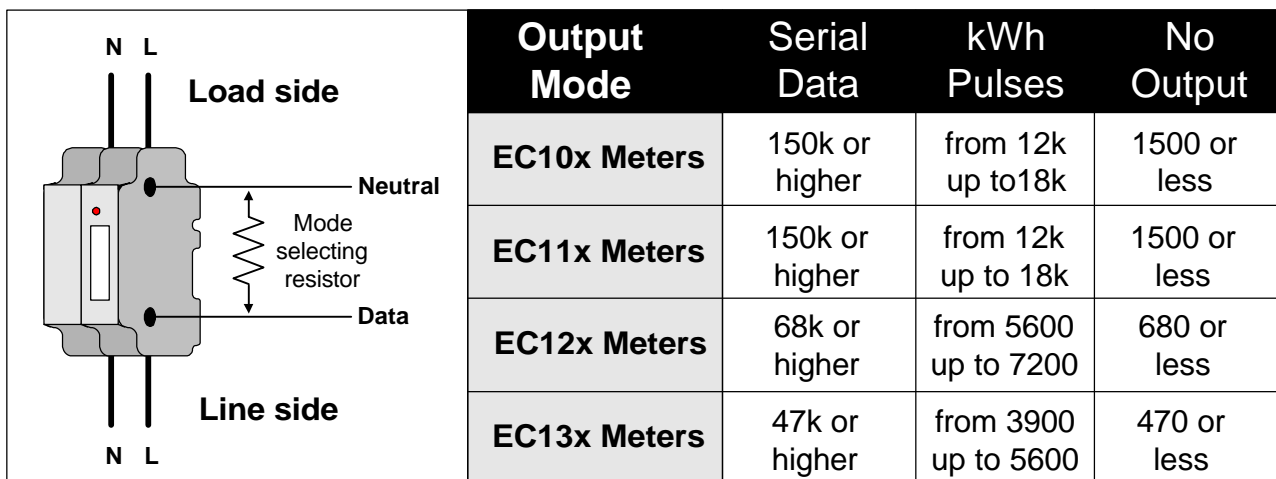

Figure 1. Location of the Lateral Data Bus (LDB) and Mode Selecting Resistor values in ohms

Mode 1: Consumption pulses

The pulse output of the meter can be used for Automated Meter Reading (AMR) installations by interfacing a number of these meters into a system, which automatically counts the pulses on the Data signal. The same pulse is also used to increment the mechanical counter within the meter. One pulse is output for every 1/10 of a kilowatt/hour consumed. The pulse output timing is shown in Figure 2. Extreme care must be taken to manage power up/down response times of the pulse acquisition system if it is desired that the mechanical counter display has to reflect the exact value determined by the AMR system. This is not recommended.

Pulse outputs are wire OR-ED for the EC12x dual and EC13x three phase meters. During operation, pulse overlap will occur on an infrequent basis when two or more meters drive the Data line low simultaneously. Because the pulse duration is short in comparison with the pulse repetition rate, negligible degradation of measurement accuracy results. Synchronization of the mechanical counter reading with the AMR reading is not possible for dual or three phase installations because pulse overlap results in lost pulses.

Using the SLMS output of the ECOLEC Series 100 Meters

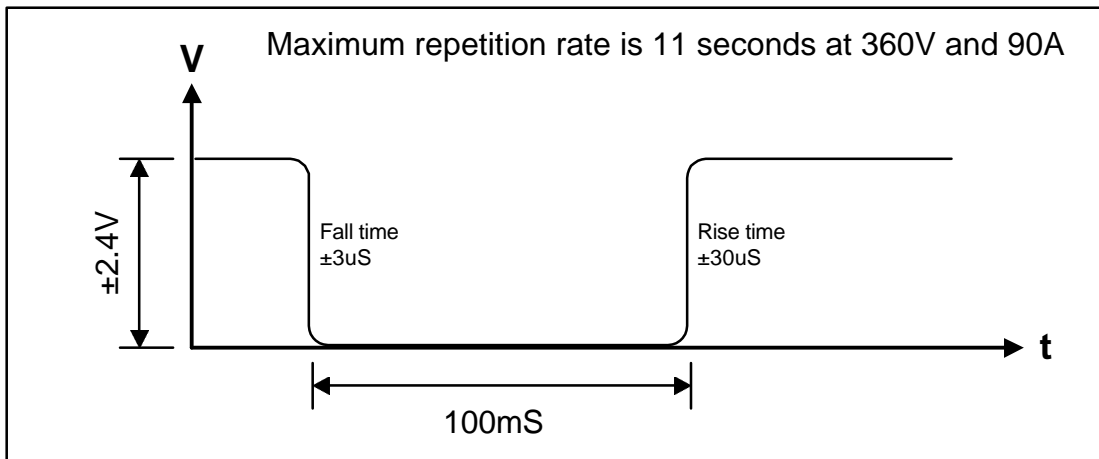

Figure 2. Consumption pulse output timing diagram

The pulse output of the meter is a low power, active low pulse referenced to the Neutral signal. The signal must therefore be buffered and isolated by the acquisition system. Long connecting wires are discouraged as they might result in transients being coupled back into the meter. A typical interface circuit using an opto-coupler is shown in Figure 3. Care must be taken to ensure that the degree of isolation provided by the opto-coupler is consistent with the impulse voltages likely to be encountered at the place of installation. Outdoor, pole top conditions are far more severe than indoor applications.

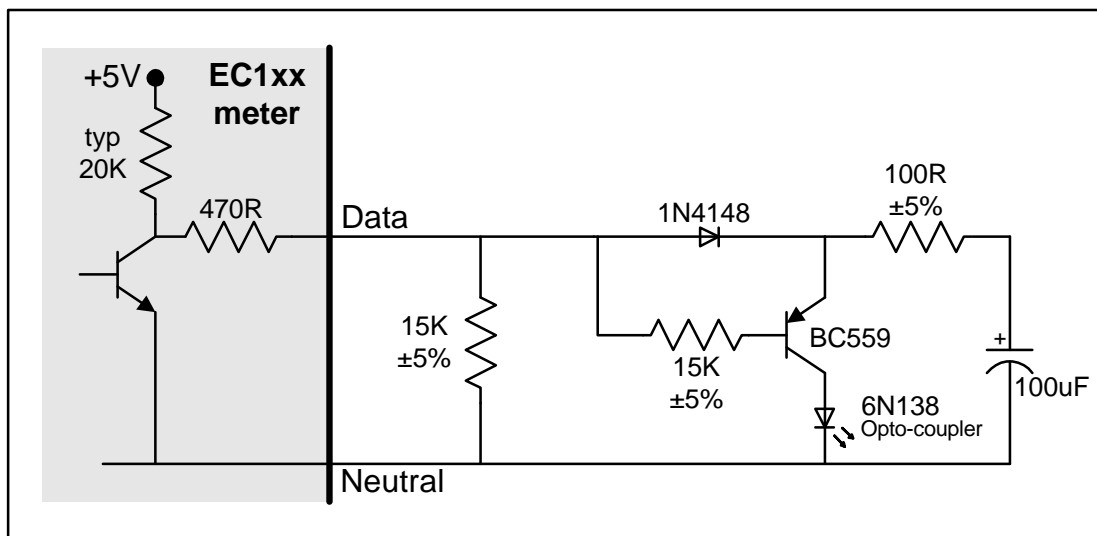

Figure 3. Typical interface circuit for a single-phase meter (15k mode setting resistance)

Mode 2: Serial data stream

The serial data output can be monitored to establish instantaneous power readings and meter status information such as serial number, manufacturer and diagnostic codes. The data stream is broadcast once a second with dynamically updated data according to the IEC1107 mode D protocol (except that a 9600 baud rate is used). The receipt of the message can be used as a one second timer event with a 1% accuracy.

Message stream overlap occurs intermittently when two or more meters transmit simultaneously onto the Data line only when using the EC12x dual and EC13x three phase meters. Because the meters run asynchronously the majority of the messages are usable. Parity and bounds checking is recommended to ensure the validity of the data received.

Using the SLMS output of the ECOLEC Series 100 Meters

The protocol stack of the serial data stream communication consists of the following three layers;

- **Physical layer**

Binary data is transmitted in accordance with standard TTL levels.

Bit Value	Signal level
0	0V – relative to Neutral
1	5V – relative to Neutral

Table 1. Serial data physical layer signal levels

- **Data link layer**

The protocol used is IEC1107 mode D (at 9600 baud). All data is transmitted as printable ASCII characters.

Parameter	Value
Baud rate	9600 bps
Start bits	1
Data bits	7
Stop bits	1
Parity	Even

Table 2. Serial data link layer parameters

The packet structure of the data stream is given below. The items enclosed in < > are not actual ASCII characters but are items as described in Table 3.

/<Company><Baud><Serial No><CR><LF><CR><LF><Message>!<CR><LF>

Item	Size	Description
/	1	Forward slash (2Fh) – Indicates start of message
<Company>	3	Company identification – “CBI”
<Baud>	1	Baud rate, leave as blank space (20h)
<Serial No>	14	Unique product serial number programmed during manufacturing Formatted as HH FF XXXX XXXX NN where HH is the hardware version (eg 12 is v1.2), FF is the firmware version (eg 13 is v1.3), XXXX XXXX is a unique hexadecimal number, NN is a family code (F1 for 120V meter, F2 for 230V meter).
<CR>	1	Carriage return (0Dh)
<LF>	1	Line Feed (0Ah)
<Message>	Variable	Application layer message – described in next section
!	1	Exclamation mark (21h) – Indicates end of message

Table 3. Package structure item descriptions

- **Application layer**

The <Message> item contains <Type> and <Data> fields, where <Type> indicates the type of data and <Data> is variable depending on <Type>.

Type	Size	Structure	Description	LED output
B	4	XXXX	Diagnostic codes (in hexadecimal – 2 bytes)	Dip count of 1
P	7	XXXX.XX	Calibrated power (in hexadecimal watts)	1000 imp/kWh
U	7	XXXX.XX	Uncalibrated power (in hexadecimal watts) <ul style="list-style-type: none"> ■ voltage over range (> 360 Volts) ■ current over range (> 90 Amps) ■ uncalibrated meter (in manufacture) 	Dip count of 8 Dip count of 9 1000 imp/kWh

Table 4. Message content type definitions

Using the SLMS output of the ECOLEC Series 100 Meters

The diagnostic codes are established and updated by a built in test sequence that runs once every second. If the meter is functioning normally, then either a 'P' or a 'U' message is transmitted. This power message contains the measured power from the preceding second. The format of the power reading is in hexadecimal characters. The integral part of the data can be directly converted, but the fractional part must be converted and then divided by 256 to get the numeric value.

When an error condition arises, the meter will transmit a 'B' and 2 bytes describing the error (see Table 5). As the meter can only transmit one <Type><Data> string per message, the 'B' message is given priority. If more than one error arises, more bits will be set and the data will indicate all of the errors that are present. The meters LED output will indicate a dip count of 1 when one or more built in test errors are detected.

Bit position	Error description	Typical cause of failure
0	Counter error	Vibration breaks a wire to the counter coil
1	I ² C bus error	Dry joint occurs in the gain setting circuit
2	Calibration table error	Repeated calibration caused an overflow
3	Family code error	Family code erroneously programmed
4	Voltage bias error	Dry joint occurs on a voltage bias part
5	Current bias error	Dry joint occurs on a current bias part
6	Voltage input failure	Lightning impulse destroys voltage divider
7-15	Reserved	

Table 5. Built-In-Test diagnostic codes

Mode 3: No output

This mode simply disables the pulse output and serial data stream output. The Data signal is pulled low by the mode setting resistor and stays there.

Conclusion

The SLMS data output by the ECOLEC Series 100 meters has many applications in AMR systems (consumption pulses) or load monitoring projects (serial data). The prime advantages of the ECOLEC meters derive from their non-volatile electromechanical display, small rail mount format and highly cost effective self-contained nature.



Figure 4. Photograph of an EC110 single-phase meter